

# THUNDER MAX EFI Throttle Body

## Building A Performance Big-Inch EFI Engine?

Zipper's ThunderMax EFI Throttle Body, Manifold and High Flow Air Cleaner assemblies provide the big airflow required for larger performance engines. These oversized CNC-machined castings replace the factory designs used on Delphi®-equipped 2001 and later models, and are designed to accept the factory electronic components so assembly is a snap. Our ThunderMax High Flow Air Cleaner includes a beautifully CNC-machined billet backplate, 2-3/4" deep high flow filter, breather plumbing and heavy-duty support brackets. Fits all years of ThunderMax throttle bodies.

**2001-2005 Models** – Throttle body and manifold are sold separately but must be used together. Throttle bodies available in 50 and 54mm; high flow design requires ThunderMax air filter with spread bolt pattern. Manifolds are available for most popular engine kits from 95" up to 124", with standard (1.625" ID) and oversize (1.780" ID) intake port options.

**2006-UP Models** – Throttle body and manifold are 1-piece, unit construction. Available in 54 and 60mm; high flow design requires ThunderMax air filter with spread bolt pattern. Manifold width available for most popular engine kits from 95" up to 124", with oversize (1.780" ID) intake port opening.

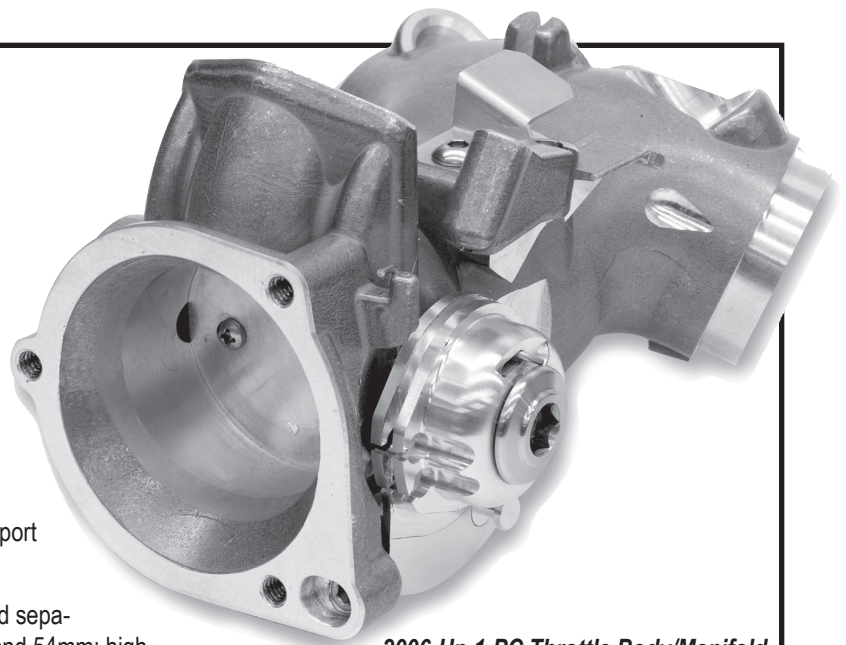

2006-Up 1-PC Throttle Body/Manifold

### 2006-UP 1-PC THROTTLE BODY/MANIFOLD

	PART No.
2006-up 54mm TB/Manifold, std length	# 109-654
2006-up 54mm f/4.980" long cylinders	# 109-655
2006-up 54mm f/5.013"-5.016" long cylinders	# 109-656
2006-up 54mm f/5.037" long cylinders	# 109-658
2006-up 60mm TB/Manifold, std length	# 109-660
2006-up 60mm f/5.013"-5.016" long cylinders	# 109-662
2006-up 60mm f/5.037" long cylinders	# 109-664
2006-up 60mm f/5.100" long cylinders	# 109-666
2006-up 60mm Max length, for cyls longer than 5.100"; machine to fit	# 109-700

### 2001-2005 THUNDERMAX THROTTLE BODIES

	PART No.
2001-2005 50mm EFI Throttle Body only	# 109-150
2001-2005 54mm EFI Throttle Body only	# 109-154

### 2001-2005 THUNDERMAX MANIFOLDS

Manifold seals included with new manifolds.

For stock length (4.937") cylinders.

Fits Zipper's 95 & 107"

	STD PORT	OVERSIZE PORT
H-D, 1 88, 95, 96, 103, 110, 113" JIMS-SE H-D® 120	# 109-609	# 109-709

For 4.975"-4.980" long cylinders.	N/A	# 109-713
-----------------------------------	-----	-----------

For 5.013"-5.016" long cylinders.	N/A	# 109-716
-----------------------------------	-----	-----------

For 5.037" long cylinders.	N/A	# 109-718
----------------------------	-----	-----------

For 5.100" long cylinders.	N/A	# 109-723
----------------------------	-----	-----------

Max length, for cyls longer than 5.100"; machine to fit.	N/A	# 109-700
--	-----	-----------

### REPLACEMENT MANIFOLD SEALS

Standard port manifolds use standard seals; oversize manifolds require special seals. Sold Each.	# 198-036	# 198-035
--	-----------	-----------

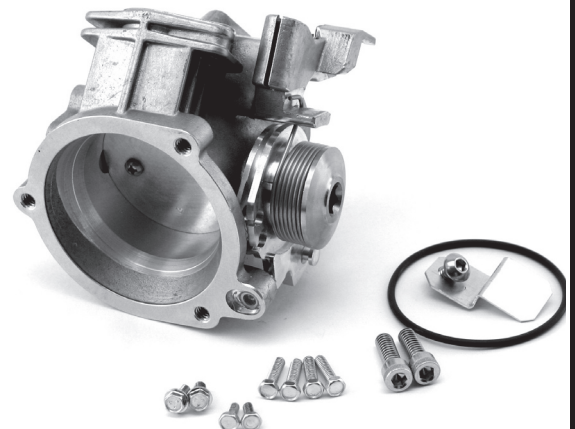

2001-2005 ThunderMax Throttle Body



2001-2005 ThunderMax Manifold w/ Seals

[www.Thunder-Max.com](http://www.Thunder-Max.com)

Legal in California only for racing vehicles which may never be used upon a highway.

# THUNDER MAX

## EFI Air Cleaners



Includes machining for MAT sensor relocation and block-off plate. Choose between two designs that accept either the stock factory elliptical cover or our traditional round EV style covers. Covers sold separately.

THUNDERMAX EFI AIR CLEANERS	PART No.
Accepts stock TC88-style 'football' cover	# 117-150
Accepts 8" round EV-style cover	# 117-154

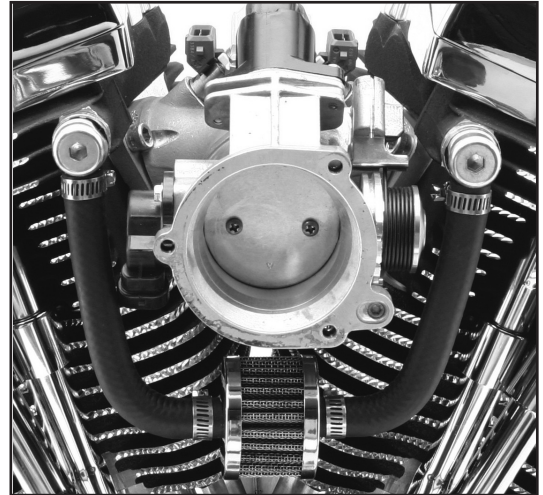

### Twin Port Breather Filter

This breather filter is designed to attach to any EV or TC88 engine that uses banjo-style fittings on the cylinder head breather ports. It attaches to the breather fittings via formed hoses and clamps and resides nearly out of sight under the carburetor or throttle body. **Simple, clean and effective!**

DESCRIPTION	PART No.
Twin Port Breather Filter kit	# 117-160



COVERS FOR THUNDERMAX AIR CLEANER	PART No.
<b>For 117-150</b>	
5 1/2" round open air filter cover, chrome smooth	# 172-780
5 1/2" round open air filter cover, chrome scalloped	# 172-781
<b>For 117-154</b>	
A. 8" round full air filter cover, chrome	# 150-291
B. 8" round full air filter cover, wrinkle black	# 150-294
C. 8" round open air filter cover, chrome scalloped	# 172-794
D. 8" round open air filter cover, chrome smooth	# 172-795
E. 8" round open air filter cover, chrome ball milled	# 172-800

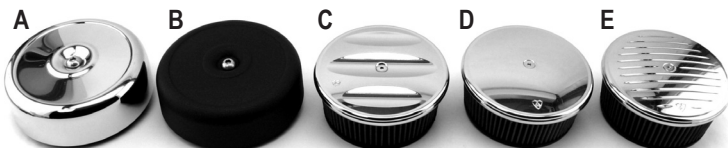

### M.A.T. Sensor Extension Harness

This extension harness will allow relocation of the Manifold Air Temperature sensor to the air cleaner backing plate from behind the throttle plate, where it is susceptible to "heat soaking" from a hot engine (our ThunderMax air filter backplates are machined to accept the MAT sensor). Fits all EFI model Big Twins. MAT sensors on 2005 and earlier models can simply be moved from the TB to the backplate; relocation on 2006-up models requires the purchase of the '95-'05 style MAT sensor listed below.

DESCRIPTION	PART No.
MAT Sensor Extension Harness	# 309-305
'95-'05 Manifold Air Temperature sensor	# 150-270

[www.Thunder-Max.com](http://www.Thunder-Max.com)

Legal in California only for racing vehicles which may never be used upon a highway.